

The reinforcement of choice for high performance marine applications.

VeTron™ High Performance Glass Roving



High performance glass – selected by professionals when only the best will do.

VeTron™ is...

- the only Advanced Material reinforcement optimized for vinyl ester resins.
- stronger than carbon fiber.
- as tough as aramid.
- as easy to process as regular glass.
- an affordable high performance solution.
- a solution for reducing weight while providing optimum protection against impact damage.





VeTron™ High Performance Glass Roving

New reinforcement for vinyl ester and polyester resins.

AGY has introduced VeTron™, a new high performance glass roving that answers the composites industry's need for a vinyl ester compatible reinforcement with higher performance than regular E-glass and lower costs than aramid and carbon fibers. *VeTron* provides superior modulus and strength for the most demanding applications. *VeTron* allows 15% more rigidity and 35% more strength than E-glass at a lower price than S-2 Glass® fiber. In addition to greater mechanical performance, *VeTron* features a lower density of less than 2.5 g/cm³, superior acid resistance to E-CR or Advantex® glass fiber with good electrical properties.



Product is available in both 36 kg package or 7 kg package

Available Products

Products are available for sampling and development.

- VE1-AB-1200X
(1200 TEX, 410 yards/lb)
- VE1-AB-2400
(2400 TEX, 205 yards/lb)

Product Application

The product is ideal for filament winding, pultrusion and weaving processes. *VeTron* will be used wherever customers need high performance reinforcement at an affordable price. From pultruded rods for reinforcing small diameter fiber optic cables to fabrics for racing boats and windmill blades, this product provides ease of processing as well as unrivaled structural performance.

Product Description

High performance glass single end roving with vinyl ester compatible sizing suitable for pultrusion, weaving and filament winding. *VeTron* rovings consist of numerous P-filament (18µ) or V-filament (26µ) continuous glass strands, gathered without mechanical twist in a single bundle.

Features

Zero catenary, smooth run out under a variety of conditions and speeds

25-35% higher strength than E-glass composites at same fiber volume fraction, 10-15% higher modulus

VeTron glass rovings have a specially engineered size that exhibits outstanding strength retention after water boil tests.

Quick wet-out

VeTron high performance glass has better acid, alkali and temperature resistance than regular glass fiber.

VeTron high performance glass is boron-free.

The new high technology manufacturing process features state-of-the-art control systems allowing unusually tight control of linear density (tex/yield).

Benefits

Excellent processing with low fuzz

Higher performance, lighter products

Resistant to water damage

The VE1 sizing system allows rapid, uniform wet out of the entire strand in vinyl ester and polyester resins. This allows the processor to optimize part fabrication time.

Durable

Environmentally friendly

Consistent product performance and reliability

Available Products

	Linear Density TEX (g/km)	Yield (yd/lb)	Nominal strand solids % w/w LOI	Filament diameter microns	Filament diameter inches	Approx. no. filaments
VE1-AB-1200X	1200	410	0.5	18	0.00075	2000
VE1-AB-2400	2400	205	0.5	26	0.00102	2000

Typical Composite Properties

VARTM Laminate of 240sy PW fabric in vinyl ester resin system.

	E-Glass Standard	VeTron VE1-AB-2400	VeTron Premium Over E-Glass
0° Tension to ASTM D638 Type III			
Average Strength ksi (MPa)	55 (379)	91 (626)	65%
Average Modulus Msi (GPa)	3.7 (25.7)	5.0 (34.0)	34%
0° Compression to SACMA 1R-94 (modified)			
Average Strength ksi (MPa)	59 (409)	76 (527)	29%
Average Modulus Msi (GPa)	4.4 (30.1)	5.6 (39.0)	28%

Packaging

Package No.	4044 Tubeless		5044 Tubeless	
	Metric	English	Metric	English
Outside diameter (O.D.)	22 cm	(8.68 in)	TBD	TBD
Inside diameter (I.D.)	16.2 cm	(6.38 in)	16.2 cm	(6.38 in)
Traverse (T)	26 cm	(10.25 in)	26 cm	(10.25 in)
Approx. pkg. weight	6.8 kg	(15 lb)	36 kg	(80 lb)
Pallet Type	Carton		Carton	
Packages/pallet	60		21	
Pallets per truckload	45		TBD	

Carton Dimension

Length (L)	110 cm	(43.3 in)	110 cm	(43.3 in)
Width (W)	110 cm	(43.3 in)	110 cm	(43.3 in)
Height with pallet (H)	94 cm	(37 in)	94 cm	(37 in)

4044 Tubeless

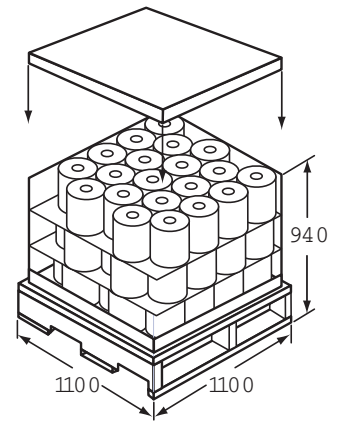
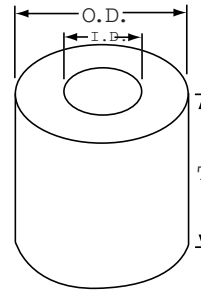

4044 in T-1100 Carton

Additional References

Customer acceptance standard RF-TBD provides additional technical information on AGY VeTron™ high performance glass rovings.



**WORLD HEADQUARTERS/AMERICAS**

AGY
2558 WAGENER ROAD
AIKEN, SOUTH CAROLINA, USA 29801
PHONE: +1.888.434.0945 (toll free)
+1.803.643.1501
FAX: +1.803.643.1180

EUROPEAN OFFICE

AGY – EUROPE
163 BOULEVARD DES ETATS UNIS
69008 LYON, FRANCE
PHONE: +33.4.72.78.1777
FAX: +33.4.72.78.1780

Disclaimer of Liability

This data is offered solely as a guide in the selection of a reinforcement. The information contained in this publication is based on actual laboratory data and field test experience. We believe this information to be reliable, but do not guarantee its applicability to the user's process or assume any liability arising out of its use or performance. The user, by accepting the products described herein, agrees to be responsible for thoroughly testing any application to determine its suitability before committing to production. It is important for the user to determine the properties of its own commercial compounds when using this or any other reinforcement.

BECAUSE OF NUMEROUS FACTORS AFFECTING RESULTS, WE MAKE NO WARRANTY OF ANY KIND, EXPRESS OR IMPLIED, INCLUDING THOSE OF MERCHANTABILITY AND FITNESS FOR A PARTICULAR PURPOSE. STATEMENTS IN THIS DOCUMENT SHALL NOT BE CONSTRUED AS REPRESENTATIONS OR WARRANTIES OR AS INDUCEMENTS TO INFRINGE ANY PATENT OR VIOLATE ANY LAW, SAFETY CODE OR INSURANCE REGULATION.

For more information, visit our Web site at www.agy.com

VeTron™ is a trademark of AGY.

S-2 Glass® is a registered trademark of AGY.

Advantex® is a registered trademark of Owens Corning.