



FIBERGLASS CONTINUOUS FILAMENT YARN FOR THE PAPER, FILM AND FOIL INDUSTRY

I. DESCRIPTION

Fiberglass yarn is a natural, lustrous, white, continuous filament yarn which is twisted on various supply packages. The yarns are smooth, non-cellular and generally cylindrical in form. The yarns are made of glass of high stability and durability and are with the exception of sizing ingredients, inorganic, incombustible and will neither expand nor contract with moisture changes. The glass composition meets the certification for "E" glass as defined by ASTM's D 578-00 Standards Specification for Glass Fiber Strands. The individual glass fibers do not tend to absorb moisture and are extremely flexible.

The sizing may be burned off the yarn under certain conditions. Weathering tests have indicated comparatively unlimited stability under repeated cycles of heat, cold, sunlight, dampness and drying.

II. USE

These yarns are used as reinforcements in the manufacture of laminates of paper, film, foils or combination thereof.

III. YARN NOMENCLATURE

Example

EC 9-134 1X0 Z20

- E- Electrical glass formulation
- C- Continuous filaments
- 9- Filament diameter (See Table 1)
- 134- grams per 1000 meters of yarn
- 1X0- Single yarn end
- Z20- Twists per meter (TPM)

ECG 37 1/0 0.5Z

- E- Electrical glass formulation
- C- Continuous filaments
- G- Filament diameter (See Table 1)
- 37- Yards per pound divided by 100
- 1/0- Single yarn end
- 0.5Z- One-half turn per inch (TPI)

Throughout history, the actual yardage or TEX of yarn products has often been shifted from the actual yield provided in the product name. Therefore, the yarn name is only used as a descriptor. The table in section V. must be utilized to obtain the actual bare glass yield of a yarn product.



Customer Acceptance Standard

No. TP-234 LD
 Date: 04-Aug-10
 Supersedes: 29-Nov-07
 Page: 2 of 6

IV. GENERAL INFORMATION

Filament Designation US Units	Filament Designation SI Units	Range for Average Filament Diameter			
		Minimum Inches	Maximum Inches	Minimum μm	Maximum μm
E	7.0	0.00025	0.000299	6.35	7.61
G	9.0	0.00035	0.000399	8.89	10.15
H	11	0.00040	0.000449	10.16	11.42

The yarns are twisted onto plastic single flange bobbins with a milk bottle type build, which is suitable for over end removal only. The bobbins are designed to provide a smooth runout, and their geometry is controlled to maintain the desired runout performance. The package build will not extend past the edge of the base. Maximum allowable undercut at the base is 3/16" (5mm). The bobbins have no defects on the nose, which would interfere with the smooth removal of the yarn.

All packages are treated to provide hang-on to within approximately 1/2" (13mm) of the bobbin barrels. The treatment is adequate to control sloughing of the yarn in both wheel and creel applications without creating excessive running tensions.

V. AVAILABLE PRODUCTS AND BARE GLASS YIELD PROPERTIES

Product Name*	Product Name (Tex Designation)	Sizing	Bare Glass Yield						
			Nom. Yds/lb.	Min. Yds/lb.	Max. Yds/lb.	Nom. Tex	Max. Tex	Min. Tex	Typical CV**
ECE 225 1/0 0.5Z	EC7 22 1X0 Z20	622	22500	21174	23826	22.0	20.8	23.4	2.0
ECG 37 1/0 0.5Z	EC9-134 1X0 Z20	620	3700	3427	3973	134.1	144.7	124.9	2.5
ECG 75 1/0 0.7Z	EC9-68 1X0 Z28	620	7300	6884	7716	68.0	72.1	64.3	2.0
ECG 75 1/0 0.7Z (1)	EC9-68 1X0 Z28	641	7600	6890	8310	65.3	72.0	59.7	2.3
ECG 75 1/0 0.7Z (2)	EC9- 68 1X0 Z28	641	7300	6884	7716	68.0	72.1	64.3	2.0
ECG 75 1/0 0.7Z	EC9-68 1X0 Z28	719	7300	6884	7716	68.0	72.1	64.3	2.0
ECG 150 1/0 0.7Z	EC9-33 1X0 Z28	620	15000	14000	16000	33.1	35.4	31.0	2.5
ECG 150 1/0 0.7Z	EC9-33 1X0 Z28	641	15000	14000	16000	33.1	35.4	31.0	2.5
ECG 150 1/0 0.7Z	EC9-33 1X0 Z28	646	15000	14000	16000	33.1	35.4	31.0	2.5
ECH 55 1/0 0.7Z	EC11- 90 1X0 Z28	641	5500	4986	6014	90.2	99.5	82.5	3.1
ECH 110 1/0 0.7Z	EC11-45 1X0 Z28	606	11000	9973	12027	45.1	49.7	41.2	3.1

- (1) on 8542 bobbins
- (2) on 8571 bobbins

- *- Nomenclature used for identification purposes only. Nomenclature may not indicate true yield.
- ** - Cv provided as a reference only. This is not a specified product property.

Additional Comments: See Section VIII for bobbin selections.



Customer Acceptance Standard

No. TP-234 LD
 Date: 04-Aug-10
 Supersedes: 29-Nov-07
 Page: 3 of 6

VI. AVAILABLE PRODUCTS AND ADDITIONAL PHYSICAL PROPERTIES

Product Name	Tex Designation	Sizing	Strand Solids			Average Tensile *		Minimum Tensile	
			Percent Strand Solids	Minimum Percent Strand Solids	Maximum Percent Strand Solids	Lbs	Newtons	Lbs	Newtons
ECE225 1/0 0.5Z	EC7 22 1X0 Z20	622	1.30	1.05	1.55	3.2	14.2	2.4	10.7
ECG37 1/0 0.5Z	EC9-134 1X0 Z20	620	1.20	0.94	1.46	17.4	77.4	13.1	58.3
ECG75 1/0 0.7Z	EC9-68 1X0 Z28	620	1.37	1.19	1.55	9.4	41.8	7.1	31.6
ECG75 1/0 0.7Z	EC9-68 1X0 Z28	641	1.00	0.74	1.24	7.9	35.2	5.9	26.2
ECG75 1/0 0.7Z	EC9-68 1X0 Z28	719	0.70	0.50	0.90	10.0	44.5	7.5	33.4
ECG150 1/0 0.7Z	EC9-33 1X0 Z28	641	1.00	0.76	1.24	4.9	21.8	3.7	16.5
ECG150 1/0 0.7Z	EC9-33 1X0 Z28	620	1.38	1.13	1.63	4.6	20.5	3.5	15.6
ECG150 1/0 0.7Z	EC9-33 1X0 Z28	646	1.27	0.95	1.60	4.9	21.8	3.7	16.5
ECH55 1/0 0.7Z	EC11-90 1X0 Z28	641	1.12	0.86	1.38	10.4	46.3	7.8	34.7
ECH110 1/0 0.7Z	EC11-45 1X0 Z28	606	1.06	0.86	1.26	7.3	32.5	5.5	24.5

Breaking Strength - The strength is expressed in pounds (newtons) per end. The minimum strengths will be the average of four breaks per package.

* The average tensile strength is provided as reference only. This is not a specified product property.

Moisture - The maximum moisture for individual packages is 0.75%.

TEST METHODS FOR PHYSICAL PROPERTIES:

The physical properties as listed in this specification shall be tested according to the methods as specified in the reference listed below:

1. Yards per Pound (Linear Density - TEX) - W-07Ea-T*
2. Ignition Loss - W-07Ea-T*
3. Breaking Strength - S-01Fm-T*
4. Twist per Inch (per Meter) - D-15A-T*.

- * Owens Corning Test Methods. Copies available upon request.
- Additional Comment: Physical test methods will soon be changed to ASTM Methods where applicable.



Customer Acceptance Standard

No. TP-234 LD
 Date: 04-Aug-10
 Supersedes: 29-Nov-07
 Page: 4 of 6

VII. AVAILABLE PRODUCTS AND VISUAL PROPERTIES

Product Name	Tex Designation	Sizing	Maximum Average Broken Filaments (360° Count)	Filament Count *	Approximate Yarn Diameter *		Twist Tolerance	
					Inches	mm	TPI	TPM
ECE 225 1/0 0.5Z	EC7-22 1X0 Z20	622	10	408	0.0079	0.201	±0.15	±6
ECG 37 1/0 0.5Z	EC9-134 1X0 Z20	620	10	816	0.0156	.0396	± 0.15	±6
ECG 75 1/0 0.7Z	EC9-68 1X0 Z28	620	10	408	0.0106	0.269	± 0.21	±8
ECG 75 1/0 0.7Z	EC9-68 1X0 Z28	641	10	408	0.0106	0.269	±0.21	±8
ECG 75 1/0 0.7Z	EC9-68 1X0 Z28	719	10	408	0.0106	0.269	±0.21	±8
ECG 150 1/0 0.7Z	EC9-33 1X0 Z28	641	10	204	0.0080	0.203	±0.21	±8
ECG 150 1/0 0.7Z	EC9-33 1X0 Z28	620	10	204	0.0080	0.203	±0.21	±8
ECG 150 1/0 0.7Z	EC9-33 1X0 Z28	646	10	204	0.0080	0.203	±0.21	±8
ECH 55 1/0 0.7Z	EC11- 90 1X0 Z28	641	10	408	0.0125	0.318	±0.21	±8
ECH 110 1/0 0.7Z	EC11- 45 1X0 Z28	606	10	204	0.0090	0.229	±0.21	±8

*The number of filaments and approximate strand diameter are for reference purposes only. Yarns are controlled according to yards per pound (linear density-TEX).

The product shall be free of the following internal or external (depending where found) characteristics.

- | | |
|-----------------|----------------------------|
| Entrapped Waste | Dirt, Grease or Oil |
| Ends Out | Mixed Yarns** |
| Damaged Yarn* | Cut Tubes |
| Unbalanced Yarn | Cracked Tubes |
| Sloughed Yarn* | Protruding Ends (start up) |
| Bad Builds | Loops |
| Water Spots | Broken Filaments (fuzz) |

* AGY accepts no responsibility for any damaged or sloughed material that is contained in a carton, which shows any evidence of physical abuse. Any carton showing evidence of having been opened from the bottom will be considered as having been mishandled by the customer. Such damage or questions of damage is the responsibility of the carrier as, according to AGY terms of sale, delivery to the carrier constitutes delivery to the customer. AGY accepts no responsibility for any damage occurring in a customer's plant.

**In the event that AGY or the customer has reason to suspect that a shipment may contain MIXED YARN, the party first suspecting such condition will notify the other, and AGY assumes responsibility for initiating appropriate action. The use of the suspect material should be discontinued pending an investigation of the facts.



Customer Acceptance Standard

No. TP-234 LD
 Date: 04-Aug-10
 Supersedes: 29-Nov-07
 Page: 5 of 6

VII. AVAILABLE PRODUCTS AND VISUAL PROPERTIES – cont'd

Visual Tolerance

1. Protruding Ends and Loops: A protruding end or loop resting on the base of the bobbin is permissible.
2. Bad Builds: The build shall not extend beyond the edge of the bobbin base and undercuts shall not exceed 3/16" (5mm).

VIII. PACKAGING WEIGHT AND METERING DATA

- ◆ Average package weight is for information only.
- ◆ All metered packages are completely splice-free. Non-metered yarn may or may not contain splices.
- ◆ Metered and non-metered material is packaged separately.

Product Name	Tex Designation	Sizing	Bobbin Type	Average Package Wt.		Shipment Makeup		Comments
				Lbs.	Kg	Ratio	Description	
ECE 225 1/0 0.5Z	EC7-22 1X0 Z20	622	8542	7.9	3.6	100%	2.0 lbs (0.91 kg) to full	
ECG 37 1/0 0.5Z	EC9-134 1X0 Z20	620	8542	8.1	3.7	80%	Mtd 29,300 yds (26,792m)	Note : 1, 2, 3
				6.3	2.8	20%	2.0 lbs (0.91 kg) to full	
				8571	19.0	8.6	80%	
ECG 75 1/0 0.7Z	EC9-68 1X0 Z28	641	8542	9.3	4.3	70%	Mtd 69,100 yds (63,185 m)	Note : 3
				7.7	3.5	30%	6.0 lbs (2.72 kg) to full	
				8571	19.4	8.8	70%	
ECG 75 1/0 0.7Z	EC9-68 1X0 Z28	620	8542	9.2	4.1	70%	Mtd 64,300yds (58,800m)	Note : 3
				7.7	3.5	30%	6.0 lbs (2.27 kg) to full	
				8571	19.4	8.8	70%	
ECG 75 1/0 0.7Z	EC9-68 1X0 Z28	719	8571	14.4	6.5	100%	2.0 lbs (0.91 kg) to full	Note: 2
				7.6	3.7	30%	6.0 lbs (2.72 kg) to full	
ECG 150 1/0 0.7Z	EC9-33 1X0 Z28	641	8542	9.0	4.1	70%	Mtd 133,170 yds (121,770m)	Note : 3
				6.4	2.9	30%	6.0 lbs(2.72 kg) to full	
ECG 150 1/0 0.7Z	EC9-33 1X0 Z28	620	8542	9.7	4.4	70%	Mtd 140,000yds (128,016m)	Note : 3
				7.6	3.5	30%	2.0 lbs (0.91 kg) to full	
ECG 150 1/0 0.7Z	EC9-33 1X0 Z28	646	8542	9.0	4.1	70%	Mtd 133,170yds (121,770m)	Note: 3
				7.7	3.5	20%	6.0 lbs (2.72 kg) to full	
ECH 55 1/0 .7Z	EC11-90 1X0 Z28	641	8542	8.7	4.0	80%	Mtd 48,105yds (43,905m)	
				7.7	3.5	20%	6.0 lbs (2.72 kg) to full	
ECH110 1/0 0.7Z	EC11-45 1X0 Z28	606	8542	9.0	4.1	80%	Mtd 95,900 yds (87,700m)	Note :
				7.7	3.5	20%	4.0 lbs (1.82 kg) to full	1, 2, 3

Notes:

1. Available with or without transfer tails. Customer order must specify when tails are required.
2. Available with treatment only.
3. Metering tolerance for all yarns is plus 3%.

(Specification subject to change without notification.)

IX. PACKAGE DESCRIPTION

The primary form of packaging utilizes a returnable plastic pallet system as shown.

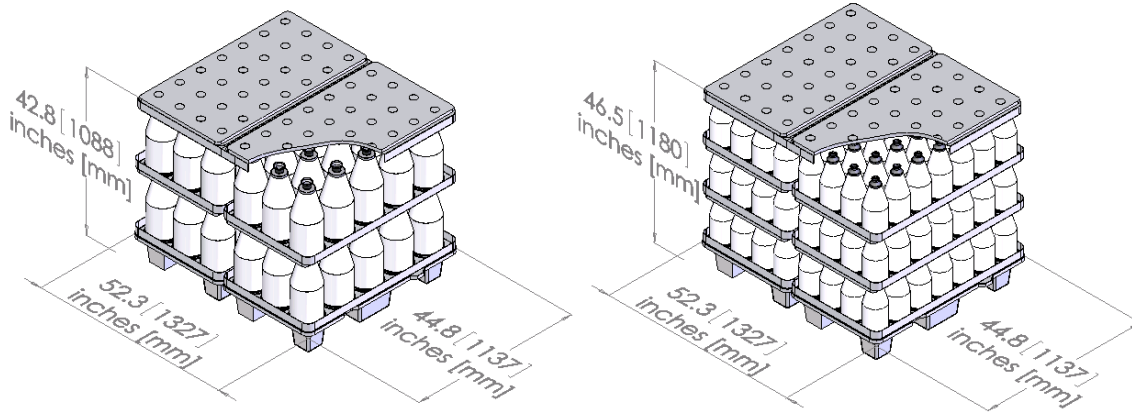

8571 Bobbins

8542 Bobbins

For additional information and details on the various types of packaging that are available, please see AGY Document AGY-PD1 (Packaging for Fiberglass Continuous Yarn).

X. PREPARATION FOR SHIPMENT

- A. Package Identification
 - 1. An identification disc will identify each package.
 - 2. The discs for the various yarn constructions will be per the system of identification set up by AGY.
- B. The packages shall be packed in a container suitable to insure adequate protection in transit and stores.
- B. A content label shall adequately identify each carton.

Document history	This is the recent history for this document.
-------------------------	---

Date	Description	Author
8/4/10	Changed solids lower, nominal and maximum limits from .85, 1.1, 1.35 to 1.05, 1.30 and 1.55.	B. Thomson