

R-310 – S-2 Glass® Roving

S-2 Glass® rovings are specifically designed and intended for filament wound or pre-impregnation applications requiring exceptional mechanical, physical, thermal, and electrical properties.

General Product Specifications

Product Information

Glass Type	S-2			S-2			
	365			449			
Binder	Epoxy, PE, VE			Epoxy, PU			
Compatibility*	9			9			
Filament Diameter - µm	250	750	1250	250	750	1250	2500
Nominal Yield	4059	4059	4059	4059	4059	4059	4059
Package	SG75	SG75	SG75	SG75	SG75	SG75	SG75
Input Sliver	30	10	6	30	10	6	3
Number of Ends	249	746	1222	245	735	1222	2444
Nominal Yield - yd/lb	1992	665	406	2025	675	406	203
Tex - g/1000 m	91	27	18	80	28	18	14
Tex Tolerance +/-	0.50	0.50	0.50	0.65	0.65	0.65	0.65
Nominal Solids - %	0.15	0.15	0.15	0.10	0.10	0.10	0.10
Solids Tolerance +/-	4.5 (11.43)	1.0 (2.54)	1.0 (2.54)	4.5 (11.43)	1.0 (2.54)	1.0 (2.54)	1.0 (2.54)
Maximum Catenary - in (cm)	0.05	0.05	0.05	0.05	0.05	0.05	0.05
Maximum Moisture - %	0.035	0.035	0.035	0.035	0.035	0.035	0.035
Maximum Fuzz - g	0.050	0.050	0.050	0.054	0.054	0.054	0.054
Nominal Package Density - lb/in ³	0.009	0.009	0.009	0.009	0.009	0.009	0.009
Package Density Tolerance +/-	70 - 90	70 - 90	70 - 90	50 - 90	50 - 90	50 - 90	50 - 90
Package Hardness Range - Shore 'O'	450 (3103)	495 (3143)	450 (3103)	450 (3103)	515 (3551)	450 (3103)	450 (3103)
Minimum Impregnated Strand Tensile Strength - Ksi (Mpa)							

Packaging Information

Package	4059	4059	4059	4059	4059	4059	4059
Nominal Package Weight - lb (kg)	16.0 (7.26)	16.0 (7.26)	15.0 (6.80)	16.0 (7.26)	16.5 (7.48)	15.0 (6.80)	15.0 (6.80)
Nominal Package Length - yd (m)	3,875 (3,543)	12,000 (10,973)	18,000 (16,459)	3,875 (3,543)	12,000 (10,973)	18,000 (16,459)	36,000 (33,098)

Rev 13, 10.27.2020

* Compatibility is resin specific, please contact your AGY representative for more details.

R-310 – S-2 Glass® Roving

S-2 Glass® rovings are specifically designed and intended for filament wound or pre-impregnation applications requiring exceptional mechanical, physical, thermal, and electrical properties.

General Product Specifications

Product Information

Glass Type	S-2				S-2		
	463				933		
Binder	Epoxy				Epoxy, Phenolic, BMI		
Compatibility*	Epoxy				Epoxy, Phenolic, BMI		
Filament Diameter - µm	9				9		
Nominal Yield	250	750	750	1250	310	750	1250
Package	4059	4059	4059	4059	4059	4059	4059
Input Sliver	SG75	SG75	SG150	SG75	SG75	SG75	SG75
Number of Ends	30	10	20	6	24	10	6
Nominal Yield - yd/lb	244	733	733	1222	307	735	1222
Tex - g/1000 m	2033	677	677	406	1616	675	406
Tex Tolerance +/-	80	29	29	20	130	38	20
Nominal Solids - %	1.00	1.00	1.00	1.00	0.23	0.23	0.23
Solids Tolerance +/-	0.16	0.16	0.16	0.16	0.10	0.10	0.10
Maximum Catenary - in (cm)	4.5 (11.43)	1.0 (2.54)	1.0 (2.54)	1.0 (2.54)	3.5 (8.89)	3.0 (7.62)	4.5 (11.43)
Maximum Moisture - %	0.03	0.03	0.03	0.03	0.06	0.06	0.06
Maximum Fuzz - g	0.035	0.035	0.035	0.035	0.035	0.035	0.035
Nominal Package Density - lb/in ³	0.047	0.054	0.054	0.054	0.055	0.055	0.055
Package Density Tolerance +/-	0.007	0.009	0.009	0.009	0.009	0.009	0.009
Package Hardness Range - Shore 'O'	50 - 90	50 - 90	50 - 90	50 - 90	60 - 110	60 - 110	60 - 110
Minimum Impregnated Strand Tensile Strength - Ksi (Mpa)	450 (3103)	495 (3143)	495 (3143)	450 (3103)	450 (3103)	525 (3620)	450 (3103)

Packaging Information

Package	4059	4059	4059	4059	4059	4059	4059
Nominal Package Weight - lb (kg)	16.0 (7.26)	16.5 (7.48)	16.5 (7.48)	15.0 (6.80)	16.0 (7.26)	15.0 (6.80)	15.0 (6.80)
Nominal Package Length - yd (m)	3,875 (3,543)	12,000 (10,973)	12,000 (10,973)	18,000 (16,459)	5,000 (4,570)	11,000 (10,050)	18,000 (16,459)

Rev 13, 10.27.2020

* Compatibility is resin specific, please contact your AGY representative for more details.

R-310 – S-2 Glass® Roving

Nominal Packaging Dimensions

Package	Pallet	Packages / Layer	Layers / Carton	Cartons / Pallet	Packages / Pallet	L -in (cm)	W-in (cm)	H-in (cm)
4059	Wood	20	3	1	60	45.0 (114.3)	31.0 (78.7)	39.0 (99.1)

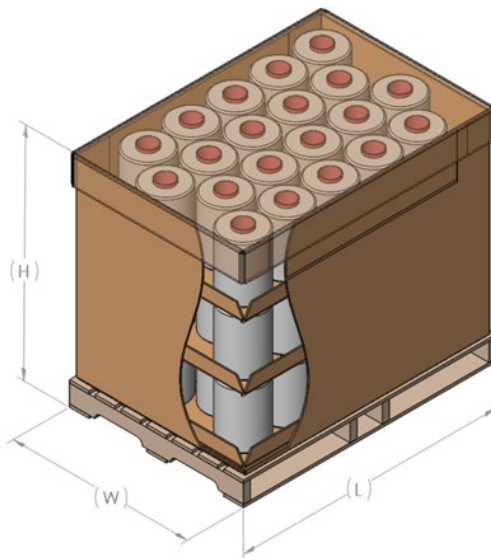

Storage, Shelf Life and Handling

Storage and Shelf Life:

AGY recommends storing the materials in accordance with appropriate safety considerations, away from exposure to the elements and at 65-80F (18-27C) and 50-70% humidity. If the materials are stored under these conditions, they are stable, non reactive and will not degrade or exhibit negative characteristics for at least 3 years from the date of manufacture. Unused, unopened product older than this is likely still in good condition, however careful evaluation is recommended. Prior to use, pallets should be placed in the production area and any plastic wrap removed for a minimum of 24 hours to allow the material to acclimate to the processing environment. Special care should be given to pallets being moved from a cold environment into a warm, humid area as condensation may occur and this additional moisture can negatively impact the runability of the material, however, once the material has acclimated, this will no longer be an issue.

For product traceability reasons, the pallet label should be recorded or retained.

Handling:

Fiberglass products process best if temperature and humidity are controlled, primarily because this will help to minimize the buildup of static electricity, fuzz and fly. AGY recommends that the material be run at 70 +/- 5 degrees F (18-27C) and 60 +/- 5% RH.

Test Methods and Certificates

A copy of test methods and or a certificate of conformity may be issued upon request.

Packages will be firmly and evenly wound on the tube, and free from defects in workmanship. AGY accepts no responsibility for damaged material that shows any signs of physical abuse.

For additional product information, refer to PTS M-711

AGY – World Headquarters / Americas
 2556 Wagener Road
 Aiken, South Carolina, USA 29801
 Phone: +(1) 888.434.0945 (toll free)
 +(1) 803.643.1501
 Fax: +(1) 803.643.1180
 Email: asktheexpert@agy.com

AGY – Europe
 Le Gemellyon Nord
 57 Boulevard Marius Vivier Merle
 69003 Lyon, France
 Phone: +(33) 4727 81775
 Fax: +(33) 4727 81780