

# R-410 – Zentron® Roving

Zentron® rovings are designed for filament winding, weaving, pultruding, or pre-impregnation applications requiring superior mechanical, physical, thermal, and electrical properties that also take advantage of the single end (low catenary) construction.

## General Product Specifications

### Product Information

Product	758-AC-1400	758-AB-675	561-AB-675
Glass Type	S-2	S-2	S-2
Binder	758	758	561
Compatibility*	Epoxy, PU	Epoxy, PU	PPS, PEEK, PEKK
Filament Diameter - μm	9	14	14
Package	4044 or 4144	4044 or 4144	4144
Nominal Yield - yd/lb	1378	671	671
Tex - g/1000 m	360	739	739
Tex Tolerance +/-	25	54	54
Nominal Solids - %	0.68	0.65	0.25
Solids Tolerance +/-	0.25	0.29	0.16
Maximum Moisture - %	0.06	0.06	0.06
Nominal Package Density - lb/in <sup>3</sup>	0.068	0.068	N/A
Package Density Tolerance +/-	0.025	0.025	N/A
Minimum Impregnated Strand Tensile Strength - Ksi Mpa	450 (3103)	450 (3103)	N/A

### Packaging Information

Package	4044 or 4144	4044 or 4144	4144
Nominal Package Weight - lb (kg)	15.5 (7.03)	15.5 (7.03)	30.0 (13.61)
Minimum Package Weight - lb (kg)	10.0 (4.54)	10.0 (4.54)	8.0 (3.63)

Rev 12, 5/5/2022

\* Compatibility is resin specific, please contact your AGY representative for more details.

# R-410 – Zentron® Roving

## Nominal Packaging Dimensions

Fig	Product	Package	Packages / Layer	Layers / Carton	Cartons / Pallet	Packages / Pallet	L -in (cm)	W-in (cm)	H-in (cm)
1	Zentron 758-AB-675	4144	12	3	1	36	45.0 (114.3)	31.0 (78.7)	39.0 (99.1)
2	Zentron 758-AC-1400	4044	20	3	1	60	45.5 (115.6)	45.5 (115.6)	37.0 (94.0)
3	Zentron 561-AB-675	4144	11	3	1	33	45.0 (114.3)	31.0 (78.7)	39.0 (99.1)

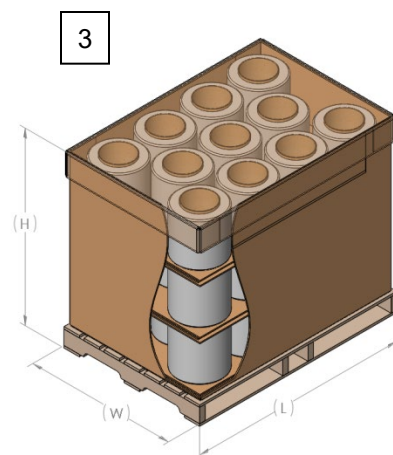
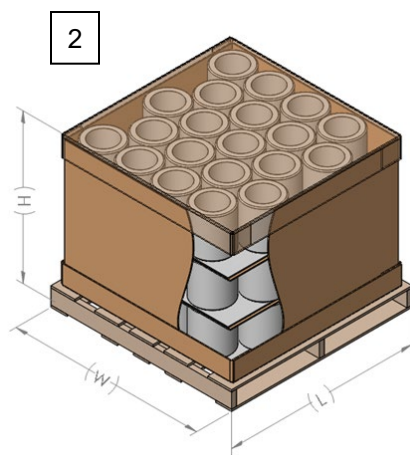
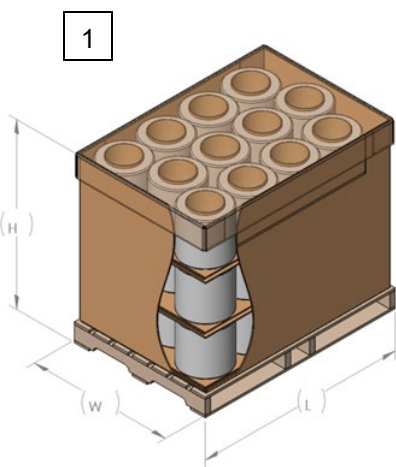

## Storage, Shelf Life and Handling

### Storage and Shelf Life:

AGY recommends storing the materials in accordance with appropriate safety considerations, away from exposure to the elements and at 65-80F (18-27C) and 50-70% humidity. If the materials are stored under these conditions, they are stable, non reactive and will not degrade or exhibit negative characteristics for at least 3 years from the date of manufacture. Unused, unopened product older than this is likely still in good condition, however careful evaluation is recommended. Prior to use, pallets should be placed in the production area and any plastic wrap removed for a minimum of 24 hours to allow the material to acclimate to the processing environment. Special care should be given to pallets being moved from a cold environment into a warm, humid area as condensation may occur and this additional moisture can negatively impact the runability of the material, however, once the material has acclimated, this will no longer be an issue.

For product traceability reasons, the pallet label should be recorded or retained.

### Handling:

Fiberglass products process best if temperature and humidity are controlled, primarily because this will help to minimize the buildup of static electricity, fuzz and fly. AGY recommends that the material be run at 70 +/- 5 degrees F (18-27C) and 60 +/- 5% RH.

## Test Methods and Certificates

A copy of test methods and or a certificate of conformity may be issued upon request.

Packages will be firmly and evenly wound on the tube, and free from defects in workmanship. AGY accepts no responsibility for damaged material that shows any signs of physical abuse.

For additional product information, refer to PTS M-711

### AGY – World Headquarters / Americas

2556 Wagener Road  
 Aiken, South Carolina, USA 29801  
 Phone: +(1) 888.434.0945 (toll free)  
 +(1) 803.643.1501  
 Fax: +(1) 803.643.1180  
 Email: asktheexpert@agy.com

### AGY – Europe

Le Gemellyon Nord  
 57 Boulevard Marius Vivier Merle  
 69003 Lyon, France  
 Phone: +(33) 4727 81775  
 Fax: +(33) 4727 81780