

# R-412 – Zentron® Muffler Fill

Zentron® Muffler Fill is specifically designed for high temperature muffler applications. It is packaged so that each of the individual roving packages are tied together and will run out as if it was one continuous end.

## General Product Specifications

### Product Information

<b>Product</b>	<b>721B-AC-250</b>
Glass Type	S-2
Binder	721B
Filament Diameter - $\mu\text{m}$	24
Package	4044
Nominal Yield - yd/lb	241
Tex - g/1000 m	2059
Tex Tolerance +/-	262
Nominal Solids - %	0.43
Solids Tolerance +/-	0.28
Maximum Moisture - %	0.06
Minimum Impregnated Strand Tensile Strength - Ksi Mpa	450 (3103)

### Packaging Information

Package	4044
Nominal Package Weight - lb (kg)	30 (13.61)
Minimum Package Weight - lb (kg)	13.5 (6.12)

Rev 3, 9/19/2022

# R-412 – Zentron® Muffler Fill

## Nominal Packaging Dimensions

Product	Package	Packages / Layer	Layers / Carton	Cartons / Pallet	Packages / Pallet	L -in (cm)	W-in (cm)	H-in (cm)
Zentron 721B-AC-250	4044	9	3	1	27	45.5 (115.6)	45.5 (115.6)	36.5 (92.7)

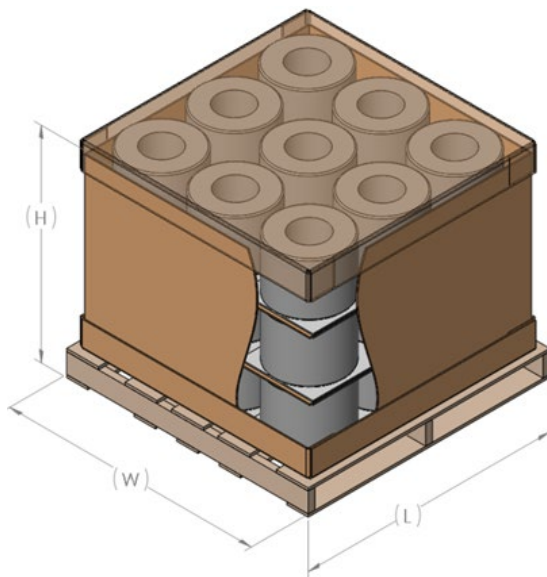

## Storage, Shelf Life and Handling

### Storage and Shelf Life:

AGY recommends storing the materials in accordance with appropriate safety considerations, away from exposure to the elements and at 65-80F (18-27C) and 50-70% humidity. If the materials are stored under these conditions, they are stable, non reactive and will not degrade or exhibit negative characteristics for at least 3 years from the date of manufacture. Unused, unopened product older than this is likely still in good condition, however careful evaluation is recommended. Prior to use, pallets should be placed in the production area and any plastic wrap removed for a minimum of 24 hours to allow the material to acclimate to the processing environment. Special care should be given to pallets being moved from a cold environment into a warm, humid area as condensation may occur and this additional moisture can negatively impact the runability of the material, however, once the material has acclimated, this will no longer be an issue.

For product traceability reasons, the pallet label should be recorded or retained.

### Handling:

Fiberglass products process best if temperature and humidity are controlled, primarily because this will help to minimize the buildup of static electricity, fuzz and fly. AGY recommends that the material be run at 70 +/- 5 degrees F (18-27C) and 60 +/- 5% RH.

## Test Methods and Certificates

A copy of test methods and or a certificate of conformity may be issued upon request.

Packages will be firmly and evenly wound on the tube, and free from defects in workmanship. AGY accepts no responsibility for damaged material that shows any signs of physical abuse.

For additional product information, refer to PTS M-711

### AGY – World Headquarters / Americas

2556 Wagener Road  
 Aiken, South Carolina, USA 29801  
 Phone: +(1) 888.434.0945 (toll free)  
 +(1) 803.643.1501  
 Fax: +(1) 803.643.1180  
 Email: asktheexpert@agy.com

### AGY – Europe

Le Gemellyon Nord  
 57 Boulevard Marius Vivier Merle  
 69003 Lyon, France  
 Phone: +(33) 4727 81775  
 Fax: +(33) 4727 81780