



AGY S2 Glass® fiber Yarn

The strongest glass fiber in the world.

AGY is a leading innovator and producer of specialty glass fibers enabling high-performance composite solutions critical to aviation, defense, architecture, and telecommunications. Flexible production operations and cutting-edge R&D allow AGY to customize solutions and develop next-generation products for your most pressing challenges.

AGY S2 Glass Yarn

This strong, resilient glass yarn is available in three basic binder systems.

- **493 binder:** Resin-compatible system allowing the yarn to be used directly in a broad range of applications, including aerospace, wire insulation, and high-performance sporting applications, such as snowboards, skis, and sails.
- **933 binder:** Resin-compatible system designed for more specialty polymers such as PEEK and Polyamide. It's also stable at higher processing temperatures. Applications include radomes and aircraft wing leading and trailing edges.
- **636 binder:** Designed for further processing such as weaving or braiding and is used in a broad range of applications, including aircraft cargo liners, high-temperature insulation, and filtration.



Product solutions

S2 Glass fibers offer a unique combination of properties: strength, impact resistance, stiffness, radar transparency, and resistance to temperature and fatigue. Compared with other reinforcing materials, S2 Glass fibers weigh less than conventional glass fiber and deliver better cost performance than aramid and carbon fibers.

Product description

AGY S2 Glass yarns consist of numerous filaments of primarily 9 microns diameter, twisted to form yarns. These yarns are then treated with either a starch-oil sizing (636), which protects the glass filaments from abrasion during further processing, or a direct size (493 or 933), which are both designed to be directly compatible with a wide variety of resin systems.

Processes

AGY S2 Glass yarns are used in a wide variety of processes, including weaving, braising, and plying. Contact your AGY representative to discover which solution is best for your application.

Features	Benefits
30% higher strength and 15% higher tensile modulus vs E Glass at the same fiber volume fraction	Consistent high performance for reliable and durable finished parts
Better fiber toughness, modulus of resilience, and impact deformation than conventional glass fiber	Improved impact capabilities to finished parts and higher composites durability and damaged tolerance
Softening point: 1056°C (1932°F) Annealing point: 816°C (1500°F) Strain point: 766°C (1410°F)	Greater fiber tensile strength and stability at elevated temperatures in thermoset and thermoplastic applications
Enhanced flexural stiffness	34% stiffer than conventional glass fiber
Excellent tolerance to damage accumulation	Ability of composite parts to withstand high levels of tension and flexural fatigue without catastrophic failure
20% reduction in dielectric constant over E Glass fibers	Radar transparency
Long shelf life, good machinability, and excellent durability	Consistent performance and reliability

Product information

Yarn type or sliver (metric)	Nominal yield (yd/lb)	(TEX)	Denier	Yarn diameter (mm)	(in)	Sizing	Sizing description
SD450 (S5 11)	45,000	11	99	0.076	0.0030	636	Starch-oil sizing for weaving and general processing
SG150 (S9 33)	15,000	33	297	0.136	0.0054	636	Starch-oil sizing for weaving and general processing
						493	Epoxy / polyester compatible
SG75 (S9 66)	7,500	66	594	0.192	0.0076	636	Starch-oil sizing for weaving and general processing
						493	Epoxy / polyester compatible
						933	Polyamides, BMI, PEEK, PEI, PPS, PES, PEK, PAI, Epoxies and LCP. Stable at processing temperatures up to 354C (670F)

All yarns are singles (1/0) with 1.0Z twist except for SG75/933, which is twisted at 0.7Z.

Nominal packaging dimensions

Bobbin	Pallet	Bobbins/layer	Layers/carton	Cartons/pallet	Bobbins/pallet	L-in (cm)	W-in (cm)	H-in (cm)
7636	Wood	18	3	4	216	45.5 (115.6)	45.5 (115.6)	45.5 (115.6)

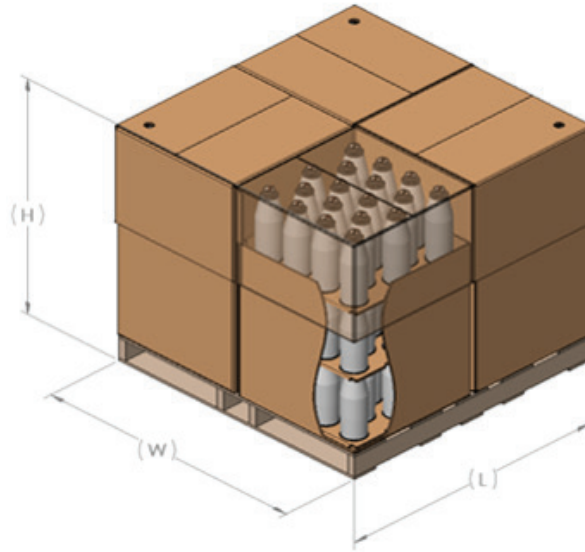

S2 Glass is a registered trademark of AGY.

www.agy.com



DISCLAIMER OF LIABILITY

This data is offered solely as a guide in the selection of a reinforcement. The information contained in this publication is based on actual laboratory data and field-test experience. We believe this information to be reliable, but do not guarantee its applicability to the user's process or assume any liability arising out of its use or performance. The user, by accepting the products described herein, agrees to be responsible for thoroughly testing any application to determine its suitability before committing to production. It is important for the user to determine the properties of its own commercial compounds when using this or any other reinforcement.

BECAUSE OF THE NUMEROUS FACTORS AFFECTING RESULTS, WE MAKE NO WARRANTY OF ANY KIND, EXPRESS OR IMPLIED, INCLUDING THOSE OF MERCHANTABILITY AND FITNESS, FOR A PARTICULAR PURPOSE. STATEMENTS IN THIS DOCUMENT SHALL NOT BE CONSTRUED AS PRESENTATIONS OR WARRANTIES OR AS INDUCEMENTS TO INFRINGE ANY PATENT OR VIOLATE ANY LAW, SAFETY CODE, OR INSURANCE REGULATION. ©2024 AGY